

WORLD MARKET®

Assembly Instructions

Marble Top Black Metal Console Table

SKU-613132

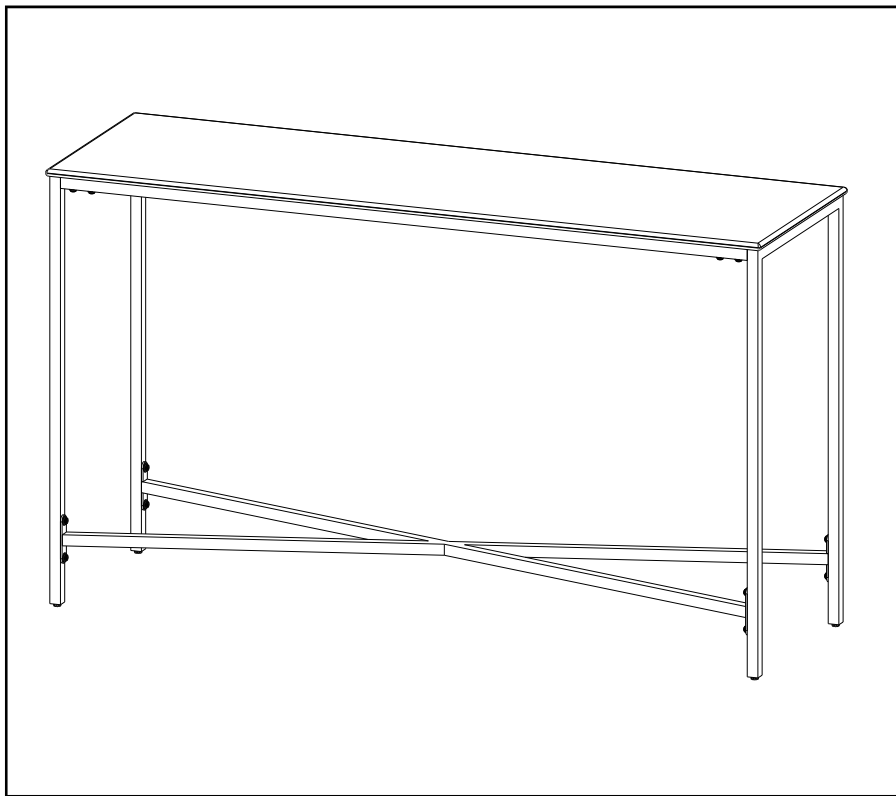

THANK YOU FOR YOUR PURCHASE. IF YOU HAVE ANY QUESTIONS
PERTAINING TO THE ASSEMBLY OF THIS FURNITURE PIECE, PLEASE CONTACT
THE NEAREST WORLD MARKET STORE.
IF YOU ARE NOT NEAR A STORE, PLEASE CALL OUR CUSTOMER SERVICE CALL
CENTER TOLL FREE AT 877- 967-5362 FOR ASSISTANCE.

NOT FOR COMMERCIAL USE

Component List

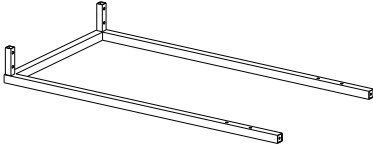
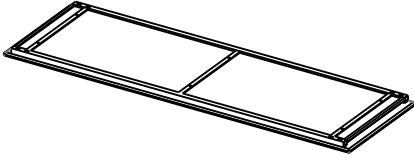
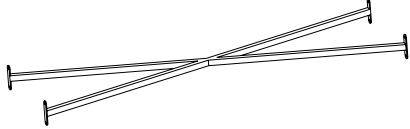
LABEL	IMAGE	DESCRIPTION	QTY
A		Leg	2
B		Marble Top	1
C		Stretcher	1

Hardware List

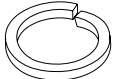
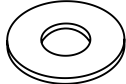
LABEL	IMAGE	DESCRIPTION	QTY
H-1		Allen Bolt (6 mm x 16 mm)	16
H-2		Spring Washer (8 mm x 12 mm)	16
H-3		Flat Washer (6.5 mm x 16 mm)	16

Tool List

LABEL	IMAGE	DESCRIPTION	QTY
T-1		Allen Key (4 mm)	1

Assembly Preparation

Before Beginning:

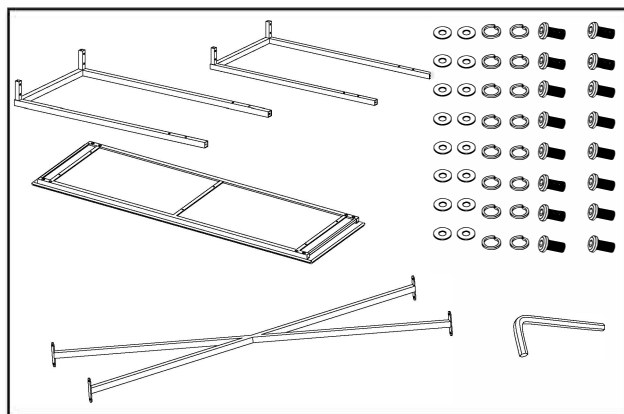

- **Unpack all hardware bags and components to ensure you have all parts.**



- **Read instructions, cover to cover.**



- **Have 2 adults on hand for assembly.**



- **Do not assemble on flooring or carpet.**



- **Assemble on a clean non-marring surface (packing foam).**



- **Save all packaging until finished.**



- **In case of missing parts, please contact your nearest World Market store or call our customer service call center at call 1-877-967-5362.**

Assembly Steps

Step-1

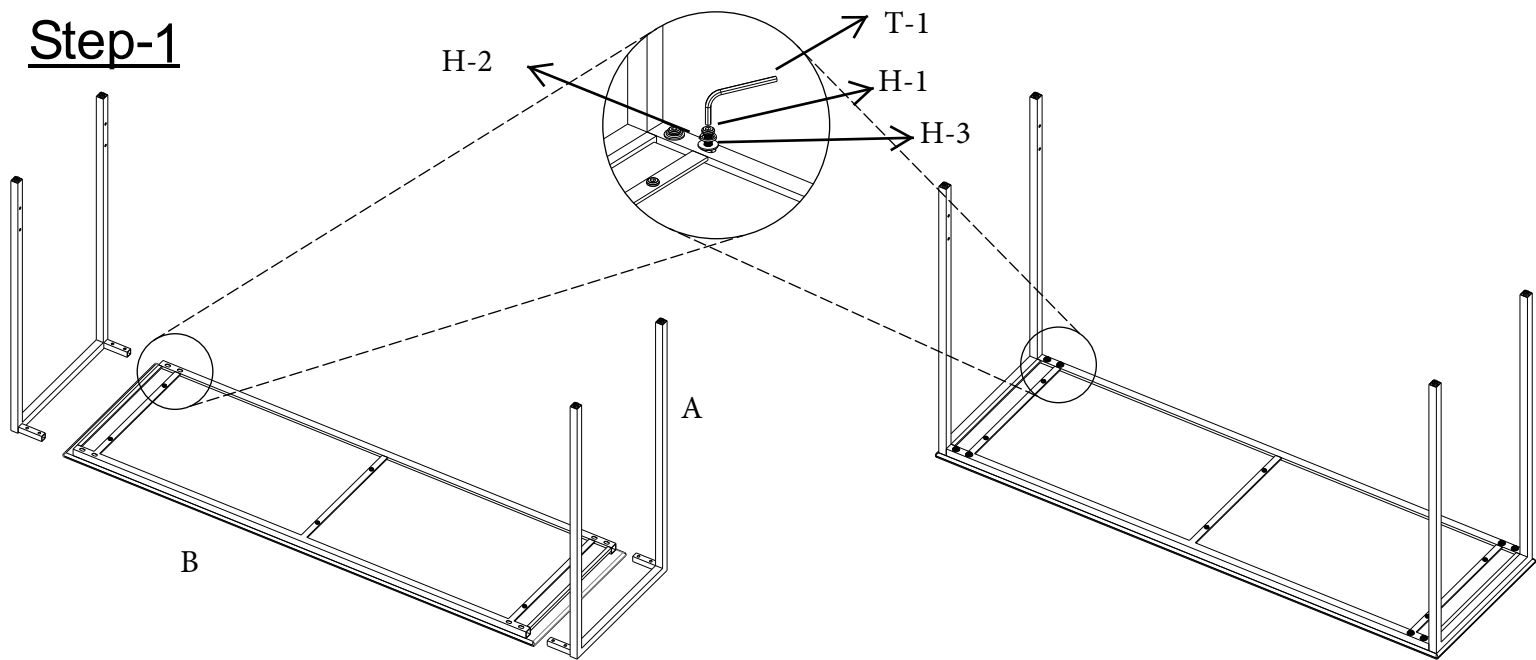

Using a second person, place the Marble Top (B) upside down on a padded non-marring surface. Gently insert the Leg (A) onto the metal pipe underneath the Marble Top (B) ensuring the holes on the Leg (A) align with holes on the metal pipe as illustrated. Secure connections using Allen Bolt (H-1), Spring Washer (H-2) and Flat Washer (H-3), stacking the hardware as shown. Repeat the same steps to assemble other leg (A). Do not yet fully tighten connections.

Step-2

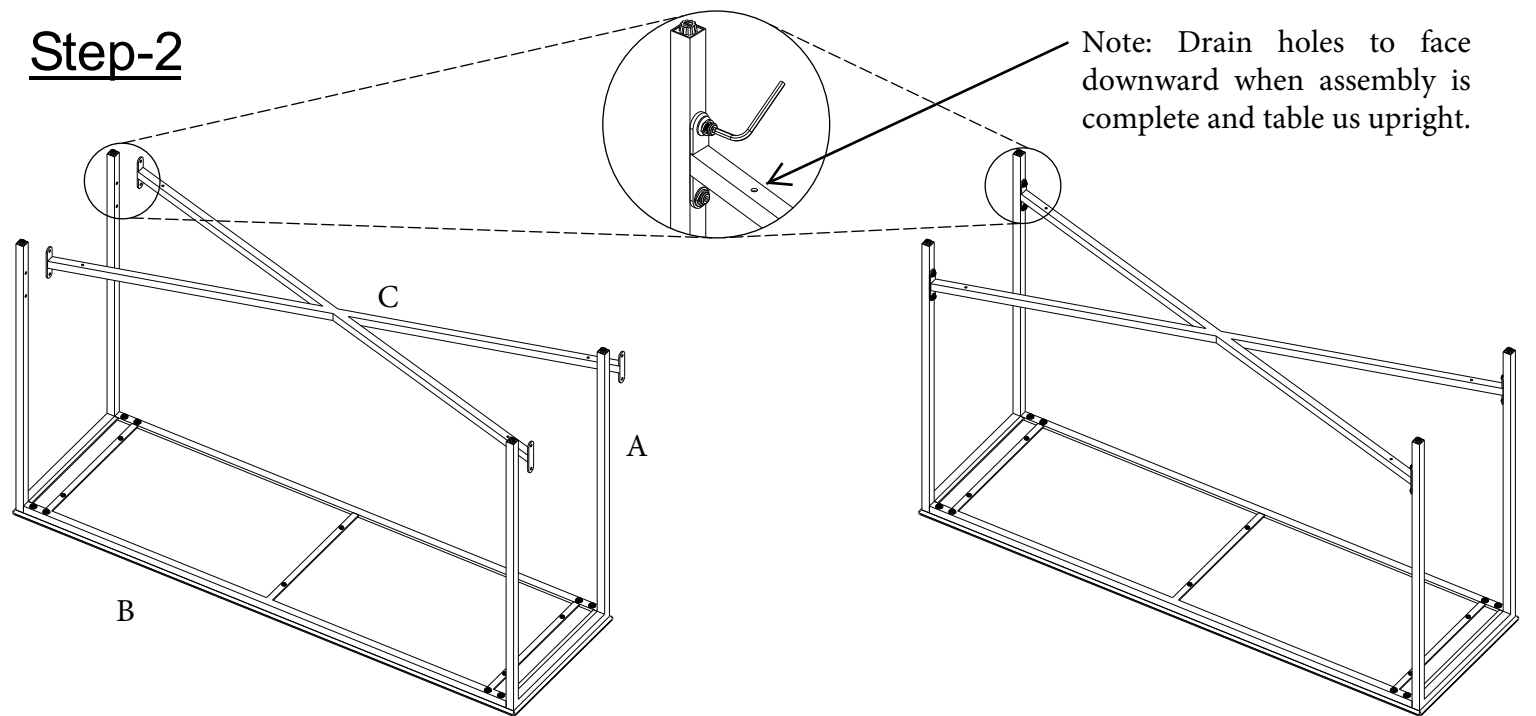

Using a second person, align the holes in Stretcher (C) with the holes in Leg (A), ensuring the drain holes in the stretcher will face downward when the assembly is complete and standing upright. Secure connections using Allen Bolts (H-1), Spring Washers (H-2) and Flat Washers (H-3). Fully tighten all connections using Allen Key (T1).

Assembly Steps

Step-3

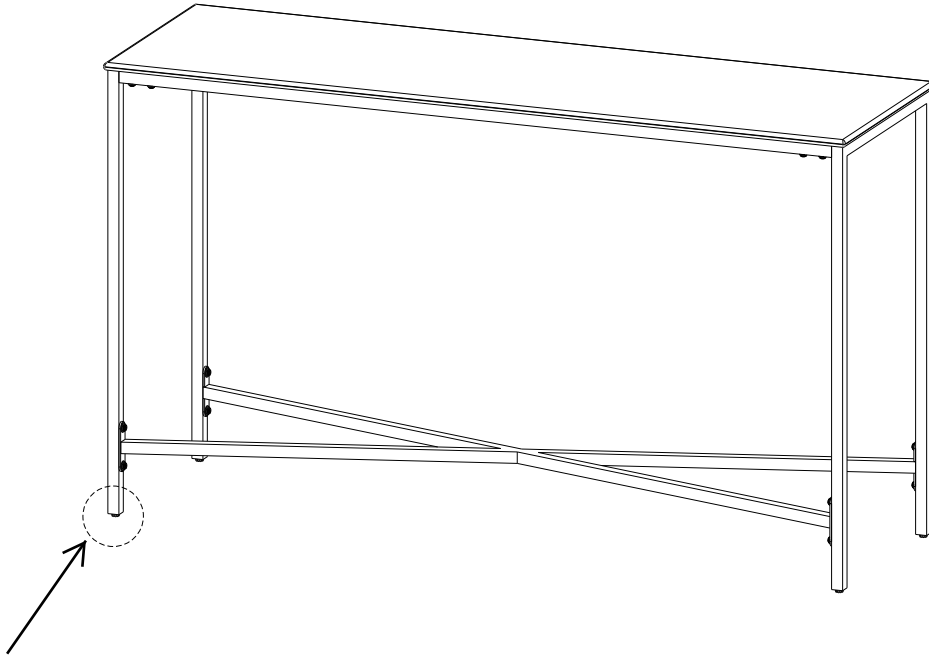

NOTE: Levelers can be used for adjustment if needed.

Using a second person, place the assembled console into the upright position. Your assembly is now complete and ready to use.

Anti-Tip Measures

Safety Strap Attachment

Warning - Children may be injured by tipping of furniture and the use of the Anti-Tip Kit is highly recommended. This Anti-Tip Kit is only a deterrent. It is not a substitute for proper adult supervision. Manufacturer and retailer assume no liability for improper installation or excess loads placed on screws, brackets, or straps. When properly installed, this restraint provides protection against unexpected tipping of furniture. This Anti-Tip Kit **MUST** be installed into the wall using proper mounting hardware OR into a wall stud using appropriate screws. Position of the Anti-Tip Kit depends on the product and the location of the wall studs. The hardware provided is not a comprehensive solution for all wall types. Be sure to consult a professional or your local hardware store to determine the hardware needed for your specific wall type (plaster, drywall, concrete, etc.).

1) Place your furniture piece in its final location along the wall. Hold the Wall Brackets (A) approximately 6 inches below the top of the piece and aligned with the legs. Mark the locations of the Wall Bracket (A) holes onto the wall. Pre drill the holes in the wall at the marked locations with a drill and drill bit (not included) roughly the diameter of the anchor. Insert the Anchors (D) into the holes until roughly flush with the surface of the wall. Align Wall Bracket holes with Anchors and secure by inserting Screws (B) into each hole and tightening using a screw driver (not included).

2) Move the furniture piece into its final location and align the legs with the brackets on the wall. Thread the Cable Tie (C) through each bracket and around each leg, as shown, and tighten until snug. NOTE: Do not over tighten.

IMPORTANT: Check that the Wall Bracket is firmly screwed into the wall and the Cable Tie is snug.

If there is any hesitation or questions, please consult a professional or your local hardware store.

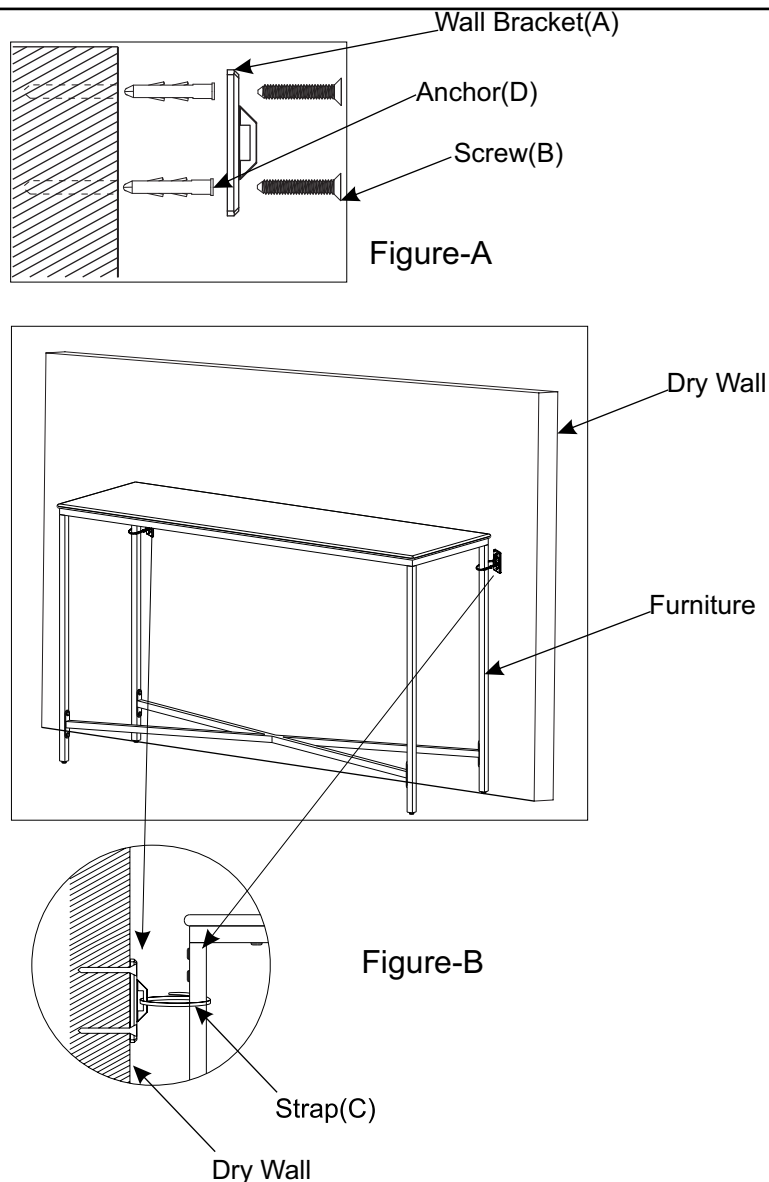
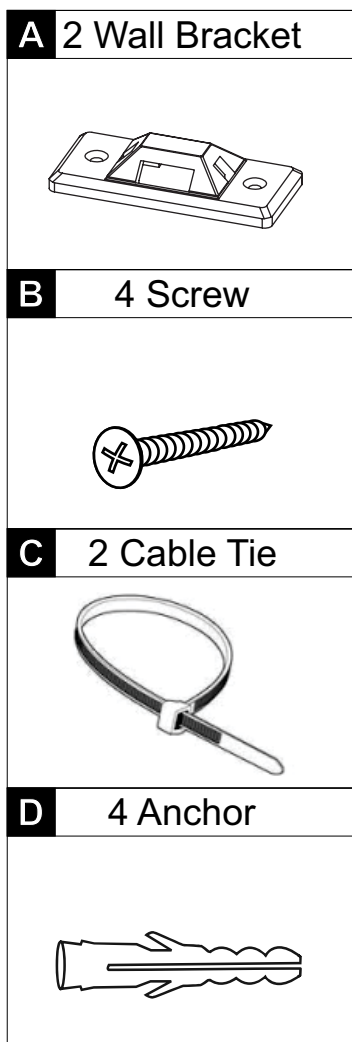

Care & Maintenance

-  • Do not put hot items directly on furniture surface.
-  • Do not clean furniture with harsh cleansers or polish.
-  • Do not place furniture in direct sunlight.
-  • Do not place furniture near heating or cooling vents.
-  • Do not write on furniture without a padded barrier to protect the surface.
-  • Do not place furniture outside. For indoor use only.
-  • Not for commercial use. For residential use only.

-
-  • Dust and pick-up spills using a clean, non-colored, lint-free cloth.

Note • Recommend using coasters to protect table top. Wipe spills immediately with a soft, dry cloth.

WORLD MARKET LIMITED ONE-YEAR WARRANTY – Indoor Furniture

For your customer satisfaction, this product carries a LIMITED ONE-YEAR WARRANTY from the date of purchase. This limited warranty only applies to World Market brand furniture, and not to other furniture brands sold on World Market's website.

Where applicable, the limited warranty provides coverage for:

1. **Manufacturing, Material and Workmanship Defects:** Includes defects related to core frame/structure substrates (wood and metal); cracking, splitting, or complete breakage of hardwood, plywood or medium density fiberboard (MDF); cracking, splitting or lifting of wood veneer or laminated top surfaces caused by process failure; broken welds or improperly coated metal frame components (powder coating or painted); fabric or leather material defects including tears, misprints, fraying, crease marks, skip stitches or open seams; support webbing material and sinuous spring defects or damage, including method of attachment to frame; and other component failures that are a direct result of manufacturing or workmanship defects.
2. **Cushions & Cushions with Enclosed Steel Pocket Coils:** Failed or ruptured steel pocket coils enclosed inside of seat cushions, or loss of resiliency from a material breakdown of foam or fiber filling, which should not be confused with softening or settling during normal use.
3. **Leather:** Splitting or cracking of leather material. NOTE: The warranty does NOT cover natural hide markings, variations in the leather color or grain due to the authentic natural properties of processed cowhide leather.
4. **Bonded Leather or Bi-cast Leather:** Separation of the polyurethane coating, peeling or cracking of the inner layer or at the bonded seam edges (bi-cast straps).
5. **Furniture Components (Hardware & Mechanisms):** Includes defects to pre-installed components or hardware provided to the customer for assembly such as office chair hydraulic lifts, lift mechanisms, metal bases and casters, swivel plate mechanisms; for drawers, metal glides, handles/knobs; for doors, hinges, magnetic latches; and other components such as bent or stripped threaded leg posts and adjustable levelers. For missing, damaged, corroded, or misplaced hardware components such as bolts or washers, please contact Customer Service at: 877-967-5362.

This LIMITED ONE-YEAR WARRANTY does NOT cover:

1. Damage due to mishandling during transportation from store or transportation without original protective packaging.
2. Abuse, negligence (product misuse) or wear and tear that may result in or from:
 - a. **Wood & Veneer:** Mishandling, exposure to moisture, peeling or discoloration caused by exposure to moisture or excessive sunlight, heat; splintered, dented or nicked panels, legs or component edges or paint/finish blemishes; or treatment with corrosive chemicals (dyes, inks, paints or harsh cleaning products).
 - b. **Fabric & Leather (Including Bonded or Bi-Cast Leathers):** cuts, punctures, tears, burns, pet damage, or treatment with corrosive chemicals (dyes, inks, paints or harsh cleaning products), exposure to direct sunlight, fire, high heat, water, or any bright light source (natural or artificial) that may cause splitting, peeling or flaking with time.
 - c. **Foam (Cushions):** Flattening, relaxing or settling/softening of foam components that comes with normal use.
 - d. **Hardware Components:** improper installation or misuse/substitution of hardware components not defined in the Assembly Instructions for the product (if applicable)
3. Damage due to environmental exposure to direct sunlight, fire, high heat, water or extreme humidity, any bright light source (natural or artificial), or any environment that the product is not intended for.
4. This warranty is applicable for indoor furniture products purchased for residential use only.

For additional information on returns, please visit: <https://www.worldmarket.com/category/customer-service/returns.do>

NOT FOR COMMERCIAL USE: Products purchased for commercial use will VOID all warranty provisions as listed above.

Any claims under this LIMITED ONE-YEAR WARRANTY are valid and applicable only as to the original purchaser and must be accompanied by proof of purchase. Warranty claims should be submitted directly to a Cost Plus World Market store or through World Market Customer Service Call Center, Toll Free at 877-967-5362.

For valid warranty claims, World Market will repair or replace the product, or offer a full or partial credit, in the sole discretion of World Market. This LIMITED ONE-YEAR WARRANTY gives you specific legal rights and you may also have other rights which vary from state to state.

(INDOOR FURNITURE UPDATED 2/23/22)